

All dimensions are imperial unless stated.

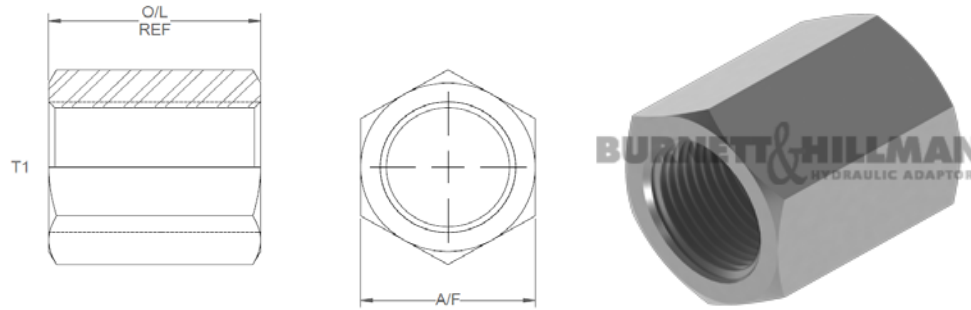

	T1	O/L	A/F
09000	1/8	1	14mm
09002	1/4	1	19mm
09004	3/8	1.135	22mm
09005	1/2	1.29	27mm
09009	5/8	1.52	30mm
09010	3/4	1.695	32mm
09011	1	2	41mm
09012	1-1/4	2.1	50mm
09013	1-1/2	2.1	55mm
09014	2	2.765	70mm
09019	2-1/2	2.76	3.25
08998	3	2.765	95mm
08993	4	2.765	5.25

DESIGN DETAILS AND SPECIFICATIONS SUBJECT TO CHANGE WITHOUT PRIOR NOTICE - Whilst every effort has been made to ensure the accuracy of the information supplied herein, Burnett & Hillman cannot be held responsible for any errors or omissions (E&OE)

A/F dimensions are imperial unless stated.

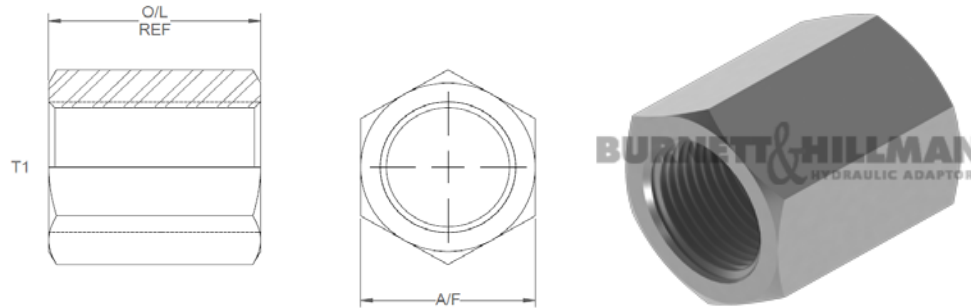

	T1	O/L	A/F
09000	1/8	25.4	14mm
09002	1/4	25.4	19mm
09004	3/8	28.83	22mm
09005	1/2	32.77	27mm
09009	5/8	38.61	30mm
09010	3/4	43.05	32mm
09011	1	50.8	41mm
09012	1-1/4	53.34	50mm
09013	1-1/2	53.34	55mm
09014	2	70.23	70mm
09019	2-1/2	70.1	3.25
08998	3	70.23	95mm
08993	4	70.23	5.25