

# Cylinders ISO 15552

Bores from 32 to 125 mm

Double acting



| Standard executions |                 |        |      |
|---------------------|-----------------|--------|------|
| Version             | Shape of barrel | Symbol | Type |
| MAGNETIC STANDARD   |                 |        | AMA  |
|                     |                 |        | AMT  |

For the magnetic reed switches type ASV see from page 1.110.1.  
For coupling cylinders/reed switches/brackets see table on page 1.120.5

For mounting accessories see from page 1.97.1.

For rod accessories see from page 1.85.1.

For dimensions of the cylinder with piston rod brake see page 1.75.15.



New series of cylinders conforming to ISO 15552 standards. They can be supplied with two different shapes of the barrel: AMA type with grooves allowing to use the flush-mounted magnetic switch and the AMT type round with tie-rods. The main features of this cylinder are the "clean" modern design and the attention to details.

A particular attention has been given to the manufacture of the end caps; there are no external casting cavities, thus eliminating contamination traps.



On request, they can be supplied according Directive 94/9/EC - ATEX

CE II 2 GDc T5

| Options  | Suffix |
|--|--------|
| Through rod (page 1.5.4)   | P      |
| Rod in stainless steel AISI 304  | K      |
| Extended rod in hardened and chrome plated steel for the application of the piston rod brake (page 1.5.4)  | B      |
| Seals FKM max 150°C (scraper ring only = V1)   | V      |
| Tandem forward movement piston rods coupled together (page 1.5.5)  | TA1    |
| Tandem forward movement piston rods independent (page 1.5.5)   | TA2    |
| Tandem back to back (page 1.5.5)   | TA3    |
| Tandem front to front (page 1.5.5)   | TA4    |
| Extended rod (indicate the requested WH dimension in mm. E.g.: WH -100).   | WH-... |
| Without adjustable cushionings   | D      |
| Adjustable rear cushioning only  | D1     |
| Adjustable front cushioning only   | D2     |
| Special male thread (indicate the requested thread. E.g. : R-M 10x1,5).<br>The dimension AM of the special thread will be the same as the standard. The cylinder will be supplied without rod nut. | R-M... |
| Female thread; for dimensions see page 1.5.4   | F      |
| With bellows for protection of the rod (in this case the dimension WH will be extended according the stroke of the cylinder)   | Z      |
| Low friction (type AMT only)   | L      |
| Piston rod tightness in nitrile rubber NBR   | H      |
| Special on request   | /S     |

The options can be combined (when this is possible).

The suffix of the options are to be added to the model number of the standard product, as shown in the following table.

How to order: 63 / 100 AMAKVR-M12x1,25

|      |   |        |      |        |        |            |
|------|---|--------|------|--------|--------|------------|
| 63   | / | 100    | AMA  | K      | V      | R-M12X1,25 |
| Bore | / | Stroke | Type | Option | Option | Option     |

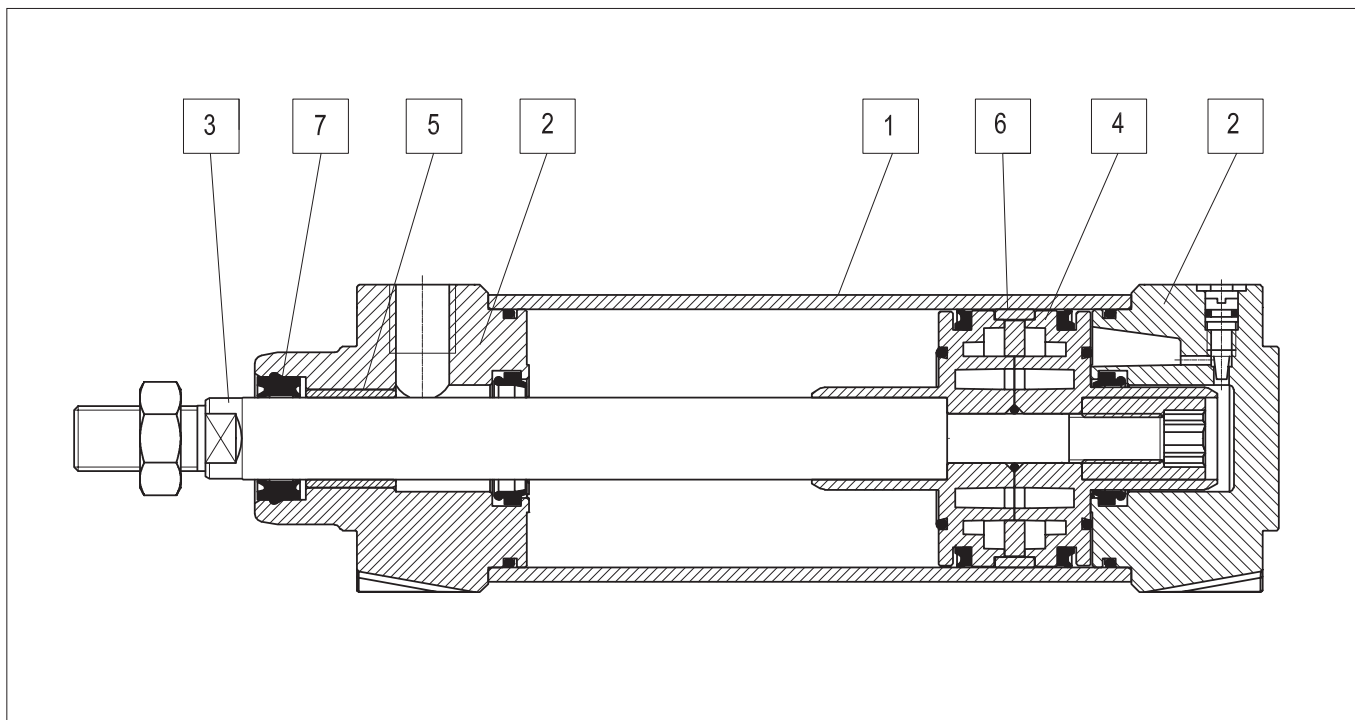

| Materials (standard types) |  |
|----------------------------|--|
| 1                          | Tube<br>Anodised aluminium                     |
| 2                          | Heads<br>Die-cast painted aluminium            |
| 3                          | Rod<br>Chrome-plated steel C45                 |
| 4                          | Piston<br>Die-cast aluminium                   |
| 5                          | Bushing<br>Self-lubricating sintered bronze    |
| 6                          | Guide ring<br>Natural Delrin                   |
| 7                          | Rod seals<br>Polyurethane                      |
|                            | Other seals<br>Nitrile rubber NBR/polyurethane |

| Technical data    |  |            |           |      |           |      |         |
|-------------------|--|------------|-----------|------|-----------|------|---------|
| Bore (mm)         | 32   | 40         | 50        | 63   | 80        | 100  | 125     |
| Fluid             | Compressed filtered air with or without lubrication. Lubrication, if be used, must be continous. |            |           |      |           |      |         |
| Pressure range    | 1 + 10 bar   |            |           |      |           |      |         |
| Temperature range | -20 °C + +80 °C  |            |           |      |           |      |         |
| Stroke            | from 10 mm to 2500 mm  |            |           |      |           |      |         |
| Cushion lenght    | 20   | 22         | 25        | 25   | 35        | 35   | 35      |
| Ports             | 1/8"   | 1/4"       |           | 3/8" |           | 1/2" |         |
| Rod thread        | M10 x 1,25   | M12 x 1,25 | M16 x 1,5 |      | M20 x 1,5 |      | M27 x 2 |
| Weight            | Stroke zero (g)  |            |           |      |           |      |         |
|                   | Additional 10 mm stroke (g)  |            |           |      |           |      |         |

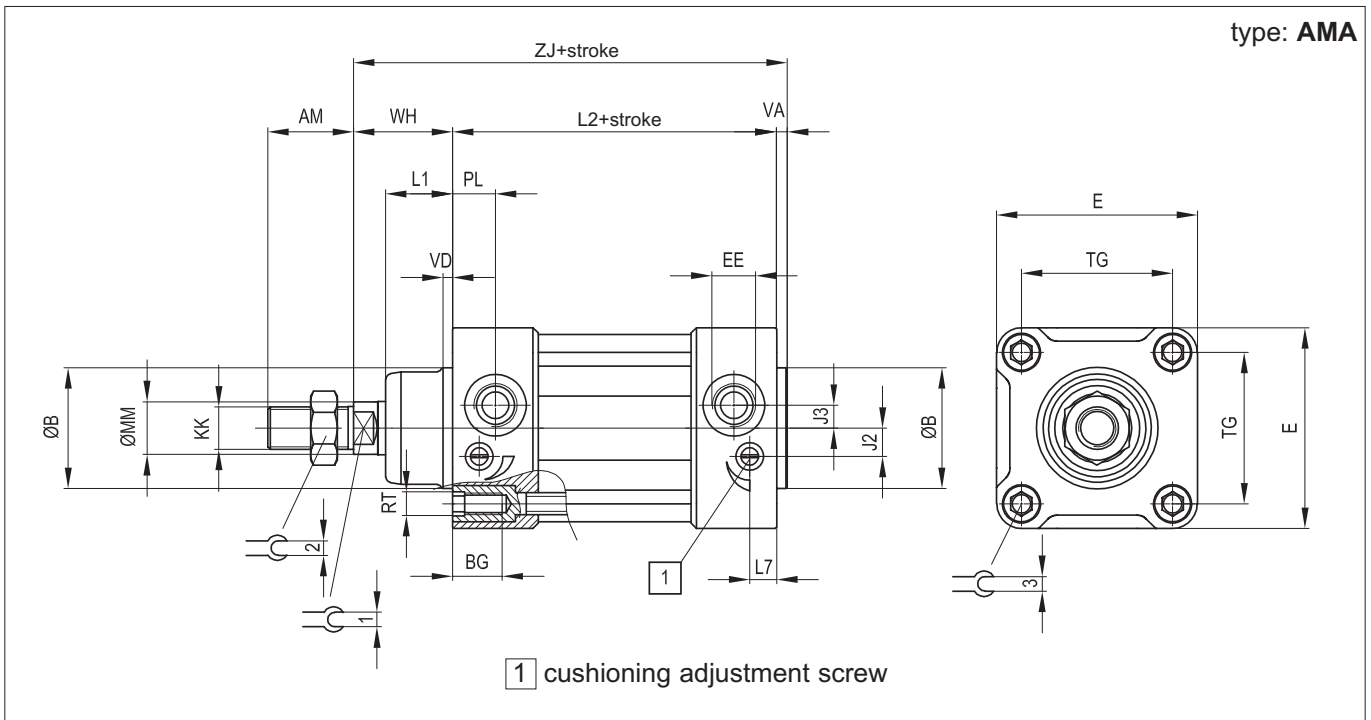

| Ø (mm) | AM | B<br>Ø d11 | BG | E   | EE               | J2   | J3  | KK       | L1 | L2  |
|--------|----|------------|----|-----|------------------|------|-----|----------|----|-----|
| 32     | 22 | 30         | 15 | 47  | G <sup>1/8</sup> | 6    | 5   | M10x1,25 | 20 | 94  |
| 40     | 24 | 35         | 15 | 52  | G <sup>1/4</sup> | 8    | 6   | M12x1,25 | 22 | 105 |
| 50     | 32 | 40         | 16 | 65  | G <sup>1/4</sup> | 10,5 | 6   | M16x1,5  | 26 | 106 |
| 63     | 32 | 45         | 15 | 75  | G <sup>3/8</sup> | 10,5 | 8,5 | M16x1,5  | 25 | 121 |
| 80     | 40 | 45         | 17 | 95  | G <sup>3/8</sup> | 14   | 9,5 | M20x1,5  | 32 | 128 |
| 100    | 40 | 55         | 17 | 115 | G <sup>1/2</sup> | 15   | 10  | M20x1,5  | 38 | 138 |
| 125    | 54 | 60         | 21 | 140 | G <sup>1/2</sup> | 20   | 10  | M27x2    | 40 | 160 |

| Ø (mm) | L7   | MM<br>Ø f7 | PL   | RT  | TG   | VA | VD | WH | ZJ  | ⌀ 1 | ⌀ 2 | ⌀ 3 |
|--------|------|------------|------|-----|------|----|----|----|-----|-----|-----|-----|
| 32     | 18   | 12         | 14   | M6  | 32,5 | 4  | 4  | 26 | 124 | 10  | 17  | 6   |
| 40     | 20   | 16         | 15   | M6  | 38   | 4  | 4  | 30 | 139 | 13  | 19  | 6   |
| 50     | 20   | 20         | 15   | M8  | 46,5 | 4  | 4  | 37 | 147 | 17  | 24  | 8   |
| 63     | 10   | 20         | 16   | M8  | 56,5 | 4  | 4  | 37 | 162 | 17  | 24  | 8   |
| 80     | 13,5 | 25         | 20,5 | M10 | 72   | 4  | 4  | 46 | 178 | 22  | 30  | 10  |
| 100    | 13   | 25         | 20   | M10 | 89   | 4  | 4  | 51 | 193 | 22  | 30  | 10  |
| 125    | 33   | 32         | 27   | M12 | 110  | 5  | 5  | 65 | 230 | 27  | 41  | 12  |

| Seal kits |  |
|-----------|--|
| n. 1      | Rod seal                               |
| n. 2      | Cushioning seal                        |
| n. 2      | Piston lip-seal                        |
| n. 1      | Linear rubber ring for piston (damper) |
| n. 2      | Tube O-ring                            |
| n. 1      | Piston guiding ring                    |
| n. 2      | O-ring for cushioning screw            |
| n. 1      | O-ring to seal two semi-pistons        |

How to order: 63 / SG / AM

|      |   |          |   |      |
|------|---|----------|---|------|
| 63   | / | SG       | / | AM   |
| Bore | / | Seal kit | / | Type |